

# Handling, Erection and Bracing of Wood Trusses

Follow these guidelines for safe installation of Wood Trusses.

These guidelines should not be considered to be the only method for erecting and bracing of a roof system. TPIC disclaims any responsibility for damages arising from the use, application or reliance on these guidelines.

## 1. Check Trusses, while they are on the ground.

- a) Count trusses to ensure that you have the correct number for the job.
- b) Measure trusses for the correct pitch, span and any special details.
- c) Check for damage, broken members, loose plates, etc.

## 2. Erection Procedure,

- a) Mark the bearing plates on both walls to the required spacing of trusses, (Normally 24" O/C).
- b) Hoist the trusses to the roof level, taking care not to bend or twist the trusses.
- c) If interior walls are available, trusses may be laid flat.
- d) If no partitions exist, trusses shorter than 32' may be inverted and hung from the bearing plates.
- e) Erect Gable or End trusses and install braces to prevent lateral movement, (See Figure below).
- f) Run a string from heel to heel of the end trusses to be used as a guide line.
- g) Erect trusses using string to locate heels. Brace each truss as it is erected.
- h) Trusses may be marked at one end. Place trusses so that all marked ends are on the same side of the building.
- i) When flat trusses are used, ensure that they are installed with the proper side up.
- j) **Install temporary bracing with sufficient X-bracing to prevent trusses from buckling or toppling over. Install permanent bracing.**
- k) Complete roof by installing roof decking, gable end ladders, etc.

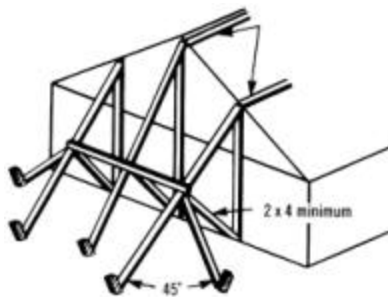

**Always provide horizontal restraint for the Top Chords**

### 3. Handling Recommendations

Trusses must be in the vertical plane to take advantage of their superior ability to support loads.

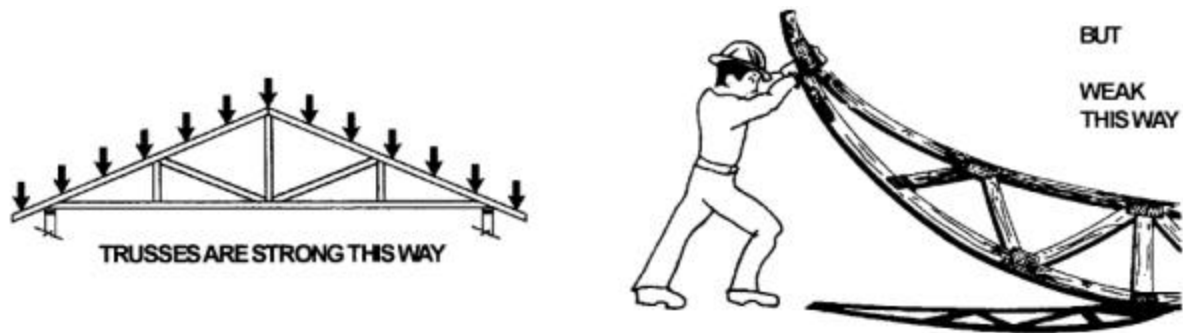

The truss erector or the builder shall take the necessary precautions to ensure that erection procedures and handling methods do not damage the trusses and thus reduce their load carrying capacity.

### 4. Mechanical Handling

Ideally when mechanical means are used, the trusses should be lifted in banded sets and lowered onto supports.

**When this method is used, extreme caution must be exercised when breaking the metal straps. Trusses may domino, lose lateral stability, or totally collapse, if temporary braces and supports are not in place before releasing the banding.**

Lifting trusses singly should be avoided, but if necessary an appropriate spreader bar should be used with slings of sufficient strength and placed in a “toed-in” position. The “toed-in” position will prevent the truss from folding.

**If erectors have any doubt, contact the truss supplier immediately.**

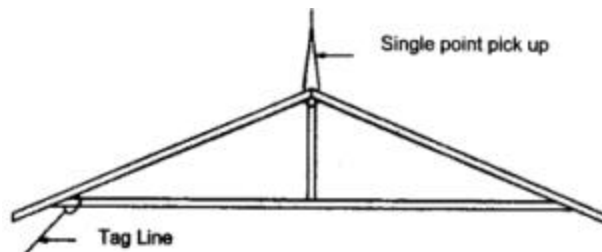

For spans of 20 feet or less, a single pick up point may be used to lift the truss. A tag line should be used whenever a truss is lifted to avoid having it swing and do damage.

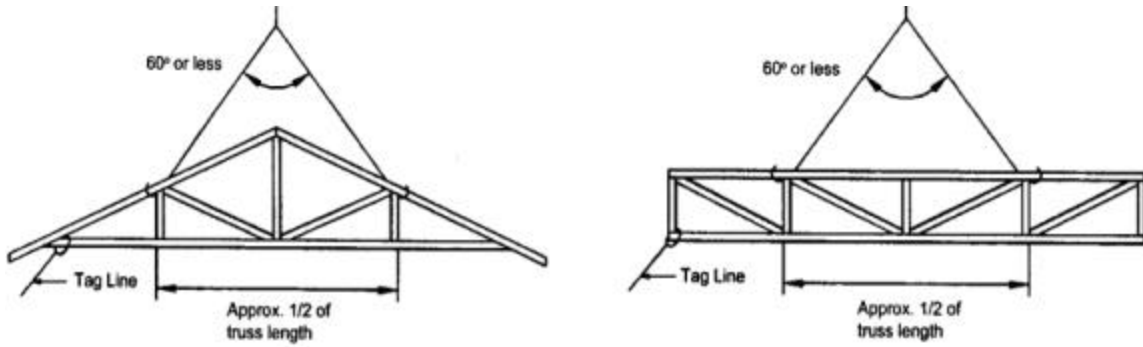

Trusses up to 30 feet in length should be lifted using two pick up points located so that the distance between them is approximately one-half the length of the truss. The angle between the two cables should be 60 degrees or less to reduce the tendency for the truss to buckle laterally during the lift. A tag line should be fastened to one end to prevent the truss from swinging and causing damage to other parts of the work or to the truss itself.

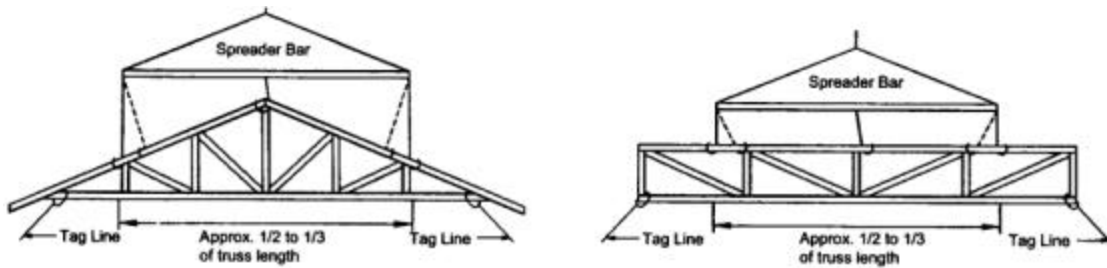

A spreader bar and short cable slings should be used to lift trusses in the 30 to 60 foot range. The cable slings may be vertical but it is recommended that they be “toed-in” to prevent the truss from folding during the lift. Two tag lines should be used to control the raining of trusses of this size.

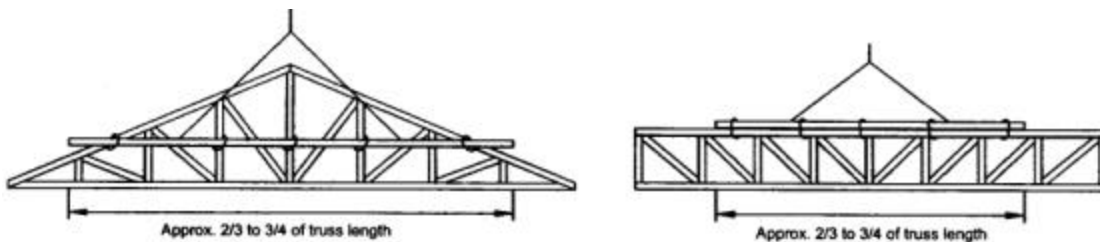

Trusses above 60 feet in length should be lifted with a strongback 2/3 to 3/4 the length of the truss. The truss should be securely tied to it at 10 foot intervals or less. For flat trusses, the strongback should be tied to the top chord. Pitched trusses should be positioned high enough on the strongback to prevent overturning of the truss. Two tag lines should be used to control the truss during lifting.

## 5. Vertical and Lateral Alignment

**ALL TRUSSES ARE LATERALLY UNSTABLE** until properly braced. The longer the span the more care required. Adequate restraint is necessary at all stages of construction.

**COMPLETE STABILITY** is not achieved until the bracing and decking is completely installed and properly fastened.

**ERECTION, BRACING AND PROCEDURES** as well as the safety of the workers are the responsibility of the erector.

**PROBLEMS MAY OCCUR** in attempts to realign trusses. Align each truss and place it permanently in position before it is connected to the bracing system. Once there is a load, even from the weight of the truss itself, large lateral forces are developed by attempts to realign the trusses. This may break the bracing system.

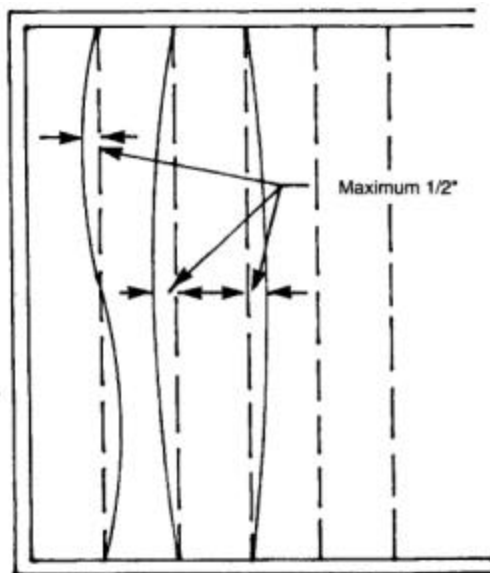

When properly aligned, each top chord should not vary more than 1/2 inch from a straight line.

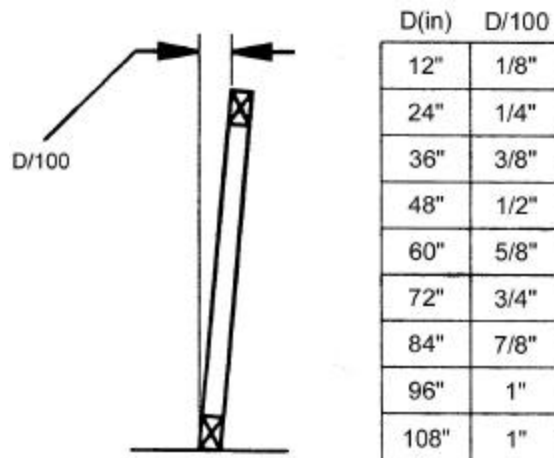

"D" = truss depth in inches.

**Out-of-plumb installation tolerances**

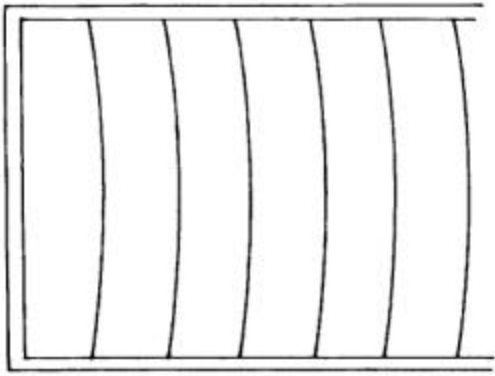

**THE BRACING SYSTEM** should provide support at spacings at no farther apart than the drawings show for the bridging. Without proper bracing trusses may not support even their own weight.

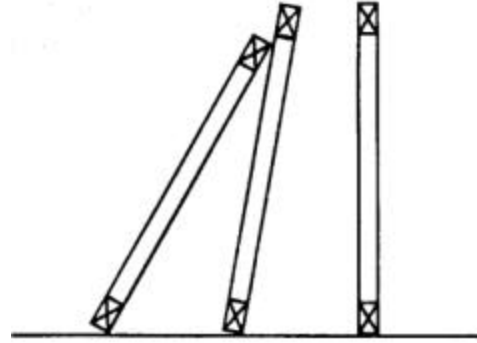

**COLLAPSE CAN EASILY OCCUR** without a bracing system that will prevent both horizontal sway (pictured to the left) or roll over (pictured above). By rolling on their sides, where they have no strength, the trusses will break or pull the ends off the bearings.

**DO NOT** permit cutting, drilling or any procedure that may damage the chords or webs.

**DO NOT** remove webs (even temporarily).

**DO NOT** make field repairs to damaged trusses without the approval of the manufacturer.

**DO NOT** overload single or groups of trusses with plywood, roofing or other construction materials or tools.

**DO NOT** erect damaged trusses. Should a truss or group of trusses fall to the ground or be damaged what so ever, do not proceed! The site engineer of note must certify that the trusses are satisfactory to erect. Notify the truss supplier immediately.

## 6. Temporary Gable End and Top Chord Bracing

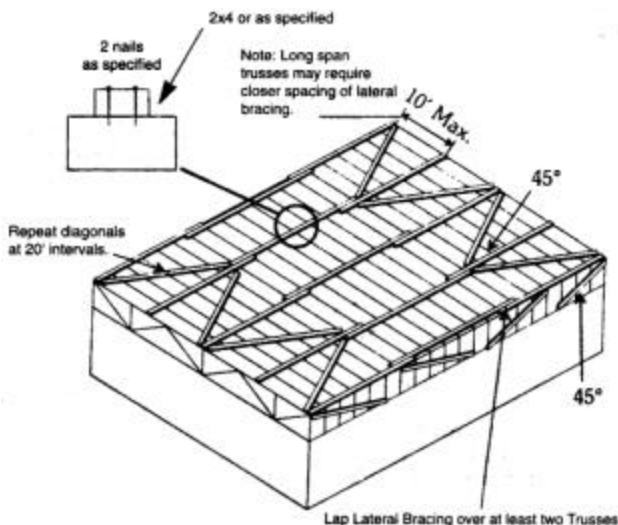

**Flat Roof Temporary Bracing**

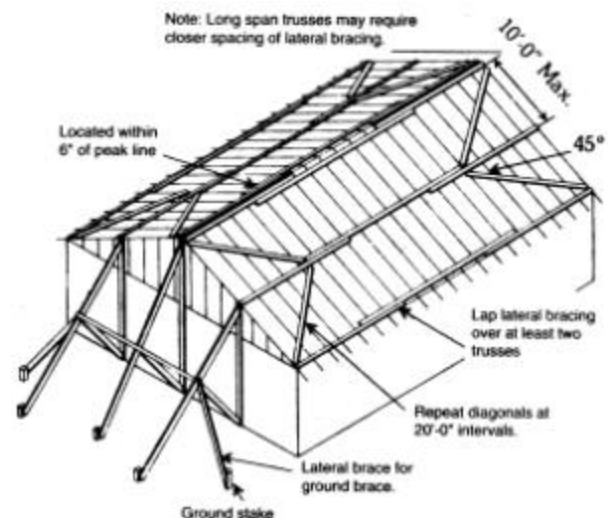

**Pitched Roof Temporary Bracing**

## 7. Laminating Girders

All girder trusses that require laminating; two plies or more, must be laminated according to the instructions on the truss design drawings or as per Appendix B, Tables B.1.1, B.1.2, B.1.3, B.1.4 and B.1.5 of TPIC Truss Design Procedures manual.

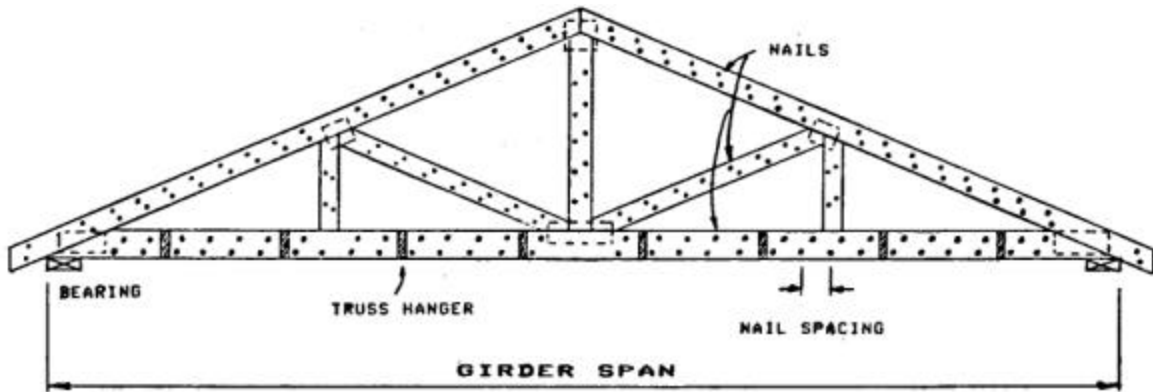

## 8. Permanent Bracing Specified by the Building Designer

Permanent bracing is designed and specified for the structural safety of the building. It is the responsibility of the building designer or an authority other than the truss designer to indicate size, location and attachments for all permanent bracing. Typical applications of permanent bracing to be specified by the building designer are as follows:

**a) Top chord bracing:**

If purlins are used, it is recommended that diagonal bracing be applied to the underside of the top chord as shown below.

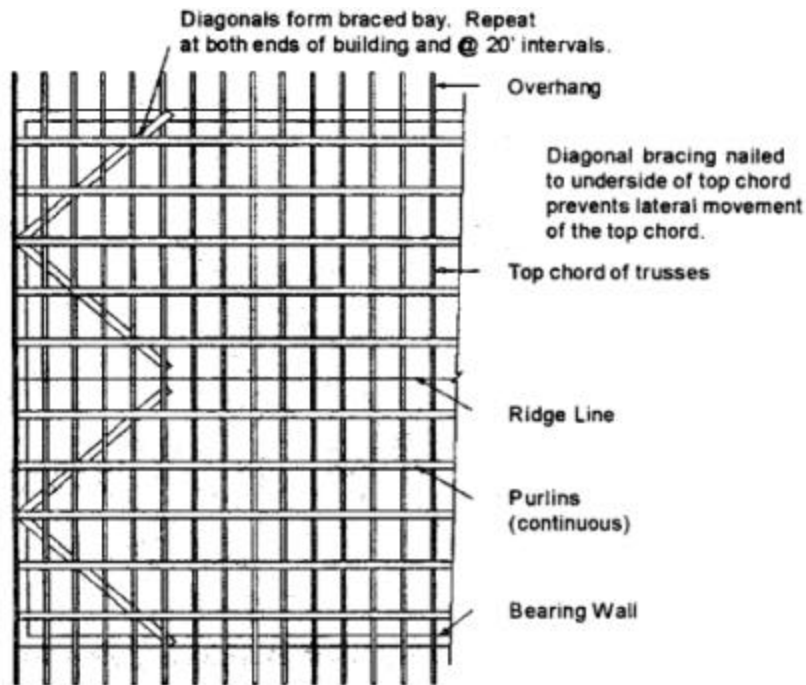

b) **Bottom chord bracing:**

This lateral and diagonal bracing is required to maintain the proper truss spacing and to transfer force due to lateral forces into the side walls, shear walls or other resisting structural elements.

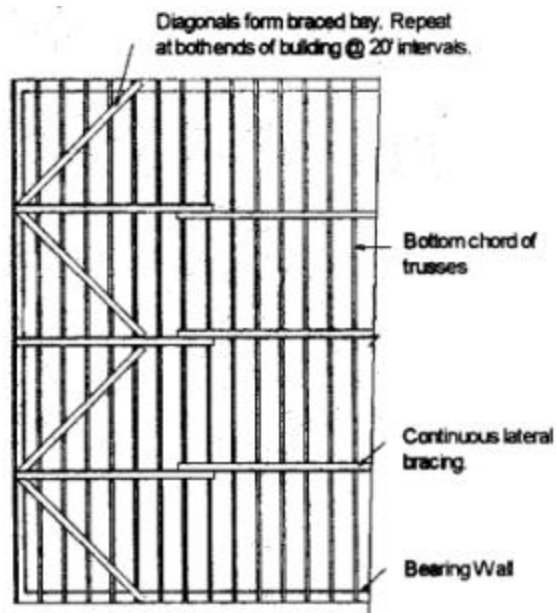

c) **Diagonal web bracing:**

The diagonal web bracing specified by the building designer is used to hold the trusses in a vertical position, to maintain the proper spacing, to distribute unequal loading to adjacent trusses and to transfer lateral forces to the diaphragms and shear walls.

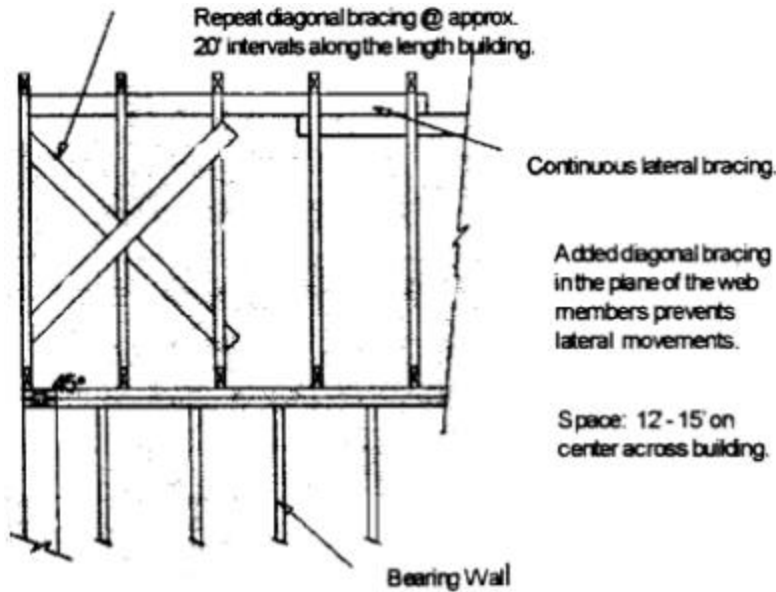

d) **Anchoring of permanent lateral web bracing:**

Permanent lateral bracing similar to that described in Section 9 must be anchored. It is the responsibility of the building designer to specify the type of anchor. A typical method of anchoring the permanent lateral web bracing is illustrated below.

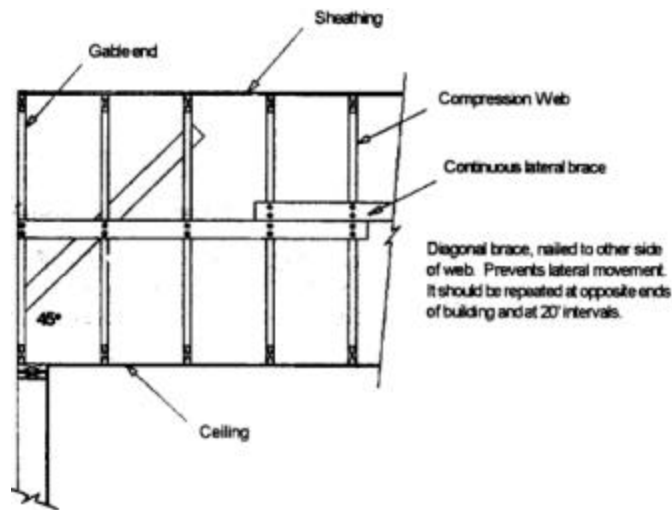



## 9. Permanent Lateral Bracing Specified by the Truss Designer

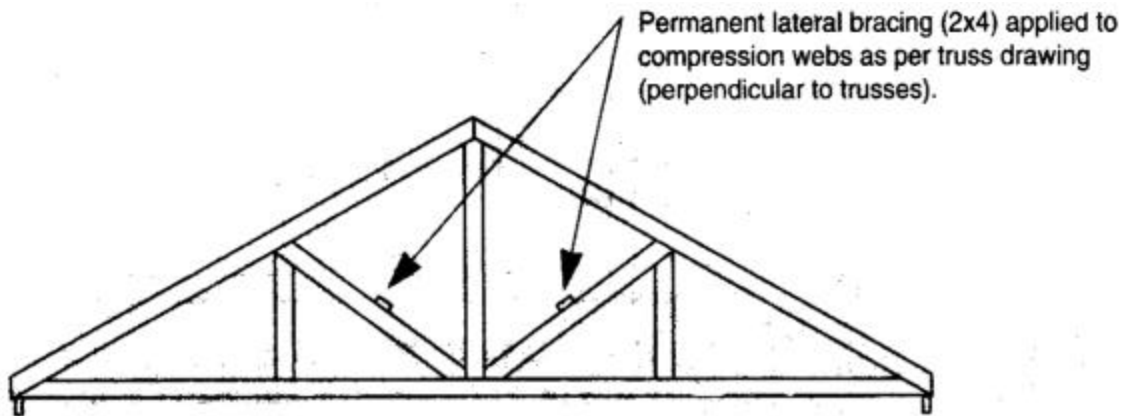

- a) All permanent lateral bracing shown on the truss design drawing must be of the size and grade as specified and must be fastened at the locations shown using the number and size of nails as specified on the truss design drawing.
- b) Lateral movement of the lateral bracing shall be restrained by permanently installing cross bracing (as shown in Section 8d) at the ends of each truss run and at intervals not exceeding 20 feet or as shown on the structural drawings.
- c) If it is not possible to install permanent lateral web bracing as specified on the truss design drawing or if the truss run is less than three trusses of the same kind, a “T” brace shall be installed as per the truss design drawing or Appendix C, Table C.1.1, of the TPIC Truss Design Procedures manual.

## 10. Top Chord Sheathing Plane

- a) **If plywood sheathing is used**, it must be applied with staggered joints and adequate nailing.
- b) **If purlins are used**, spacing should not exceed the design buckling length of the top chord and should be adequately attached to the top chord.
- c) **If Valley Sets, Conventional Framing, Piggyback Trusses, etc.**, are installed on top of the main trusses, the full length of the top chords of these trusses must be restrained by sheathing or purlins spaced as specified on the structural or truss design drawings. Top chords of trusses must always be restrained from lateral movement.

## RECOMMENDATIONS

While the recommendations for handling, erection and bracing contained herein are technically sound, it is not intended that they be considered the only method for erecting and bracing of a roof system. Neither should these recommendations be interpreted as superior to or a standard.

These recommendations originate from the collective experience of leading technical personnel in the wood truss industry, but must, due to the nature of responsibilities involved, be presented only as a guide for the use of a qualified building designer, builder or erection contractor. Thus, the Truss Plate Institute of Canada expressly disclaims any responsibility for damages arising from the use, application, or reliance on the recommendations and information contained herein by building designers or by erection contractors.

***FOR A COMPLETE PROFESSIONAL JOB READ ALL PRECEEDING INSTRUCTIONS.***

**The Truss Plate Institute of Canada would like to acknowledge the contribution of the work done by the Western Wood Truss Association of Alberta in the preparation of this document**